



# Ladder Installation Instructions

P/N 210494 & 210495: 2007+ Mercedes Sprinter Track Mounted Ladder

## Before you begin:

- *Stainless steel hardware may bind together when tightening — apply an anti-seize assembly lubricant to the threads of each bolt before assembly*
- *Over tightening bolts can cause the hardware to break due to excessive force. When tightening, be sure to apply only the recommended torque.*
- **Threaded inserts (350483) and lower attachment bracket (350558) will not be covered under warranty. Replacements can be ordered for additional cost.**
- *The ladder is designed to fit in front of the rear wheel on the driver's side of the van.*
- *Factory or aftermarket roof tracks must be installed before to ladder.*

## Required Tools:

- Standard and metric wrench set
- Standard and metric socket set
- Standard hex key (Allen wrench) set
- Drill with drill bits

## Included Hardware:

**PRE-KITTED 350452**

P/N	Description	Quantity
70008	¼"-20 Nylon-Locking Stainless Steel Nut	7
70009	¼"ID Stainless Steel Washer	10
70019	5/16"-18 Nylon-Locking Stainless Steel Nut	2
70020	5/16" ID Stainless Steel Washer	2
70060	¼"-20 x 1" Stainless Steel Button Head Screw	3
70201	5/16"-16 x 1" Stainless Steel Socket Cap Screw	2
70246	Antiseize bolt lubricant packet, 2g	1

## Additional Parts:

PN	Description	Quantity
350567	Upper Attachment "L" Brackets	2
350558	Lower Attachment Bracket	1
350483	Threaded Insert	2

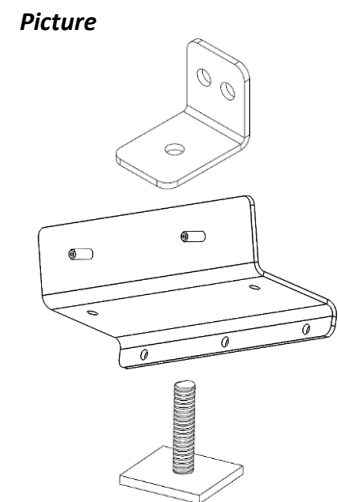
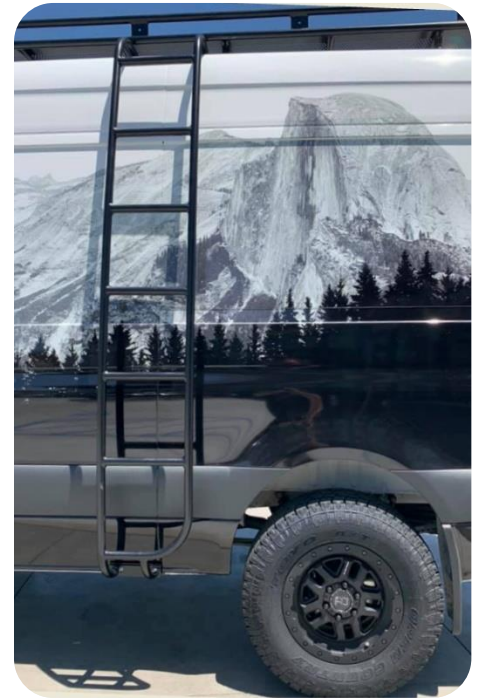



### Ladder Installation:

NOTE: If you purchased an accompanying pair of nerf bars, it is easier to install the **ladder** first.

#### Upper Attachment Installation:

1. Slide both threaded inserts into the roof track from the rear of the vehicle with studs pointing upwards.
2. Install the "L" brackets onto threaded inserts using the centered, pre-drilled holes and thread on washer and nut. Leave the "L" brackets loose enough to slide back and forth (see Figure 1) NOTE: Be sure to apply anti-seize to the threaded inserts.



Figure 1: "L" Brackets Installed on Factory/Aftermarket Tracks

3. Position the ladder where you would like it to sit on the vehicle.
4. Clamp the top of the ladder to the L-brackets using C-clamps or spring clips with "L" brackets on inside face of ladder (see Figure 2).



Figure 2: Ladder Positioned on "L" Brackets

5. Install the 5/16" bolts, washers, and nuts and tighten by hand—do not torque down bolts yet.

#### Lower Bracket Installation:

6. With the ladder attached at the top, locate the desired position of the lower attachment bracket. Ensure the ladder is straight compared to the vehicle before finalizing lower bracket placement.

7. Hold the lower attachment bracket up to the vehicle body using C-clamps or spring clips. Be sure to align the bottom three holes with the pinch weld.



Figure 3: Lower Bracket Installation

8. Using a ¼" drill bit, make three holes through the pinch weld using the bracket as a template for alignment.
9. Install the ¼" cap screws, washers, and nuts into the drilled holes. Tighten down bolts to 6 ft-lbs. of torque. NOTE: **BE CAREFUL** to not over tighten and be sure to apply anti-seize to the cap screws.
10. Place ladder against lower attachment bracket making sure the bottom of the ladder aligns over the threaded studs.
11. Install ¼" washers and nuts onto the threaded studs.
12. While applying downward pressure to the ladder, tighten the ¼"-20 nuts to 6 ft-lbs. of torque fixing the ladder in place. NOTE: **BE CAREFUL** to not over tighten and be sure to apply anti-seize.



Figure 4: Lower Bracket Tightening Technique.

13. Visually inspect the position of the ladder—if satisfied, tighten down the top bolts to 6 ft-lbs. of torque for the ¼" hardware and to 11 ft-lbs of torque for the 5/16" hardware.
14. Check all fasteners for fitment after 50 miles of driving, and periodically thereafter. Enjoy!



Scan QR code to  
download instructions



info@aluminess  
(619) 449-9930

Aluminess Products, Inc. (Aluminess) Warranty

1. Lifetime Warranty. Aluminess provides a lifetime warranty of its products to the original retail purchaser provided such products are installed correctly according to the official Aluminess installation instructions. Any modification to the original product design, function or use of any Aluminess products will void the Aluminess warranty. Aluminess will have sole discretion to determine warranty eligibility for any and all Aluminess products sold to any purchaser.
2. Limited Remedies. Subject to any limitations and exclusions described herein, and subject to Aluminess' determination of warranty eligibility, Aluminess will remedy defects in product materials and/or workmanship of any product by repairing or replacing such defective product, which shall be within Aluminess' sole discretion, without charge for parts or labor. Aluminess may elect in its sole discretion not to replace a defective product and issue the purchaser a refund equal to the purchase price of any defective product or purchaser may elect to receive a credit (equal to such refund) toward the purchase of new Aluminess products. Repair or replacement of a defective product or providing a refund or credit to purchaser will be purchaser's exclusive remedy under this warranty. Damage to a purchaser's vehicle, cargo and/or any other person or property is expressly excluded from the Aluminess warranty.
3. Modification. Aluminess products are designed to be mounted to factory equipped vehicles. Aftermarket additions to such vehicle may or may not require modification of an Aluminess product. The Aluminess warranty does not extend to any Aluminess products that are modified to fit around other otherwise accommodate or be compatible with any aftermarket vehicle accessories or alterations. Aluminess does not guarantee fitment with any other aftermarket accessories or modified vehicle, and it is up to purchaser to determine fitment prior to purchasing any Aluminess product.
4. Damage. Damage to Aluminess products due to normal wear and tear, including, but not limited to, cosmetic issues and superficial scratches, or structural damage to an Aluminess product in connection with any vehicle collisions or other structural degradation in connection with the use of such vehicle (on road or off road) will not be covered by the Aluminess warranty. Any product user's misuse, neglect, overloading, improper maintenance or improper installation or repair of any Aluminess products are not covered under the Aluminess warranty. Furthermore, broken studs are not to be covered under warranty, anti-seize and proper torque specs must be followed. Replacement kits may be delivered to the customer upon request at an additional cost.
5. Use of the Products. Aluminess products are designed for off road vehicle use. Installing Aluminess products on a vehicle may exceed the factory designed capabilities of such vehicle and could potentially lead to vehicle damage. Aluminess will not be responsible for any damage caused to a purchaser or user's vehicle or any vehicle accessories caused by the use of any Aluminess products. It is to the sole responsibility of purchaser to inspect and ensure that the intended vehicle and Aluminess products are suitable and compatible for travel on road and off road. No seller nor any manufacturer of Aluminess products will be liable for any loss, damage or injury directly or indirectly arising from the use of any Aluminess products. Before using any Aluminess products, the purchaser or user will determine the suitability of the product(s) for their intended use(s) and the purchaser or user shall assume all responsibility and risk in connection therewith.
6. DISCLAIMER. THE ALUMINESS WARRANTY IS EXPRESSLY MADE IN LIEU OF ANY AND ALL OTHER WARRANTIES, AND EXCEPT FOR THE ALUMINESS WARRANTY SET FORTH HEREIN, ALUMINESS MAKES NO WARRANTY WHATSOEVER WITH RESPECT TO ANY ALUMINESS PRODUCT, INCLUDING ANY WARRANTY OF MERCHANTABILITY AND FITNESS FOR A PARTICULAR PURPOSE, WHETHER EXPRESS OR IMPLIED BY LAW, COURSE OF DEALING, COURSE OF PERFORMANCE, USAGE OF TRADE, OR OTHERWISE.  
  
EXCEPT FOR PURCHASER'S LIMITED REMEDIES SET FORTH HEREIN, IN NO EVENT WILL ALUMINESS BE LIABLE FOR ANY LOST PROFITS, LOST SALES, OR FOR ANY CONSEQUENTIAL, DIRECT, INDIRECT, INCIDENTAL, SPECIAL, EXEMPLARY OR PUNITIVE DAMAGES OR FOR ANY OTHER DAMAGES OF ANY KIND OR NATURE.
7. Compliance. Aluminess cannot guarantee that its products comply with all Federal, State, and/or local laws. Purchaser is advised to review local vehicle codes for compatibility prior to purchase to ensure that the installation and use of any Aluminess products does not violate any applicable laws.
8. Warranty Claim Submission. Purchaser will responsible for returning any defective product to Aluminess for warranty consideration and purchaser may be responsible for all costs associated with shipping the product to and from Aluminess. Prior to returning any product for warranty, purchaser must contact Aluminess Products Inc. for proper authorization.