

Front Bumper Installation Instructions

P/N 210267: 2015+ Ford Transit

Before you begin:

- *Stainless steel hardware may bind together when tightening—it is recommended that you apply an anti-seize assembly lubricant to the threads of each bolt before assembly*
- *This installation requires two people*
- *A hawse fairlead will be required for running the front bumper and a hidden winch mount together.*



Required tools

- Standard wrench set
- Leveling tool
- Drill ¼" bit
- Sawzall

Included hardware

Quantity

• 70036--½" x 1.5" Grade 8 Bolt	12
• 70081--½" x 1.75 Grade 8 Bolt	4
• 70033--½" Grade 8 Nylock Nut	16
• 70035--½" Washer	32
• 70031--3/8" x 2" Stainless Steel Bolt	2
• 70024--3/8" Stainless Steel Nylock Nut	2
• 70028--3/8" Stainless Steel Washer	4
• Antiseize Packet, 2g	1

Included Parts

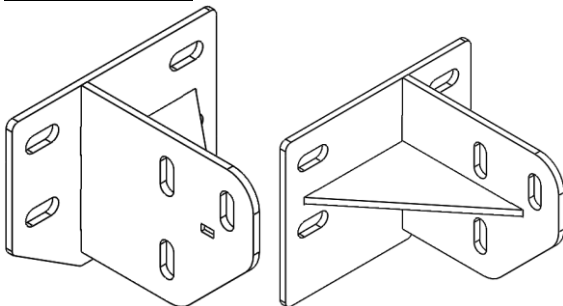

QTY: 1 Set
**Transit Front Mounting
 Brackets (DR & PS)**

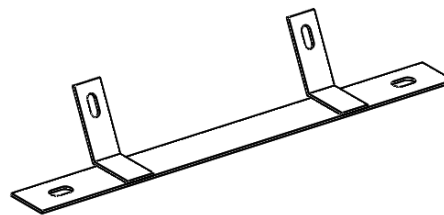

QTY: 1
**Transit Undercarriage
 Support Bracket**

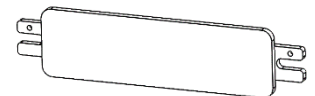

QTY: 1
**Fairlead Cover
 (pre-installed)**

Installation Instructions

1. There are a lot of plastic clips and fasteners that hold the factory equipment to the vehicle. If you are pulling on something and it doesn't want to come off the fastener likely needs to be depressed from the back side of the panel.
2. Start by unclipping the fender flare from the plastic bumper cover. These are located in the wheel well.
3. Remove the screw holding the fender flare to the bumper cover in the corner above the tire. (Pictured to the right)
4. Unclip and remove the inner fender lining which will give you access to the fender flare clips.
5. Open the van door and unclip the fender flare from the fender.
6. From inside the wheel well you can unclip the rest of the fender flare from fender. (Pictured to the right)
7. Remove the bolts holding the bottom of the bumper cover to the plastic undercarriage.
8. Remove the 2 bolts holding the undercarriage protection to the body. There is also a clip holding an AC line to the undercarriage



protection. (Pictured to the left)

9. Remove the undercarriage protection.

10. Remove the upper splash shield on the driver side. There is 1 clip and 1 bolt holding it to the body.

11. Remove the headlights by removing the 2 bolts that hold each headlight on. Be sure to unclip the wiring harness from the light and set it aside.



12. Remove the 2 bolts holding the plastic bumper cover to the fender located underneath the headlight
13. Remove the metal clips securing the bumper cover to the front grill surround.
14. Drill out the 2 rivets holding the license plate bracket to the bumper cover.
15. Remove the 2 caps covering bumper cover bolts
16. Remove the 2 bolts holding the front of the bumper cover
17. Gently pry the plastic clips that hold the bumper cover to the grill surround. (Pictured to the right)



18. Start from each fender and work your way to the center. It may be helpful to use a flathead screwdriver to get between the grill surround and the bumper cover. Gently push down on the bumper cover while you pull it away from the vehicle.

19. As you pull the bumper away from the vehicle, unclip the temperature sensor from the bumper.
20. Remove the 8 bolts securing the upper bumper to the frame.
21. Pop off the 2 clips holding the plastic to the top of the bumper
22. There are 2 spot welds that hold the upper bumper to the frame. (Pictured to the left) These will need to be drilled out or cut in order to get the bumper off the vehicle. There are 3 methods that can be used to break the spot welds



- a. Using a small right-angle drill, you can drill out each spot weld
 - b. Using a long drill bit, drill through the bumper and into the spot weld
 - c. Gently pry the bumper away from the frame exposing enough area to get a Sawzall blade between the bumper and the frame and cut through the spot weld.
23. With the factory bumper removed you can now install your Aluminess Bumper.
 24. Install the Aluminess steel bumper brackets to the frame (but do not tighten down).
 - a. ***Be sure to use the longer bolts (1.75") on the passenger side 2 outer-most holes when attaching the mounting brackets***
 25. Slide the Aluminess bumper in between the brackets and loosely fasten the 1/2" hardware into the bumper.
 26. Level the bumper and then tighten the bolts to the mounting brackets.
 27. Clip the temperature sensor into the oval hole on the back of the light tube
 28. Install the undercarriage bracket to the lower bumper using the 3/8" hardware. (Picture to the right)
 29. Install the undercarriage protection to the body using the factory bolts. Use the other factory bolts to hold the undercarriage protection to the bracket provided by Aluminess.
 30. Hold your fender flare up to the body and mark where you would like to trim them. We prefer to start low because it will allow you to trim more if you don't like the way it looks.
 31. Enjoy your new Aluminess Bumper!



Aluminess Products, Inc. (Aluminess) Warranty

1. Lifetime Warranty. Aluminess provides a lifetime warranty of its products to the original retail purchaser provided such products are installed correctly according to the official Aluminess installation instructions. Any modification to the original product design, function or use of any Aluminess products will void the Aluminess warranty. Aluminess will have sole discretion to determine warranty eligibility for any and all Aluminess products sold to any purchaser.
2. Limited Remedies. Subject to any limitations and exclusions described herein, and subject to Aluminess' determination of warranty eligibility, Aluminess will remedy defects in product materials and/or workmanship of any product by repairing or replacing such defective product, which shall be within Aluminess' sole discretion, without charge for parts or labor. Aluminess may elect in its sole discretion not to replace a defective product and issue the purchaser a refund equal to the purchase price of any defective product or purchaser may elect to receive a credit (equal to such refund) toward the purchase of new Aluminess products. Repair or replacement of a defective product or providing a refund or credit to purchaser will be purchaser's exclusive remedy under this warranty. Damage to a purchaser's vehicle, cargo and/or any other person or property is expressly excluded from the Aluminess warranty.
3. Modification. Aluminess products are designed to be mounted to factory equipped vehicles. Aftermarket additions to such vehicle may or may not require modification of an Aluminess product. The Aluminess warranty does not extend to any Aluminess products that are modified to fit around other otherwise accommodate or be compatible with any aftermarket vehicle accessories or alterations. Aluminess does not guarantee fitment with any other aftermarket accessories or modified vehicle, and it is up to purchaser to determine fitment prior to purchasing any Aluminess product.
4. Damage. Damage to Aluminess products due to normal wear and tear, including, but not limited to, cosmetic issues and superficial scratches, or structural damage to an Aluminess product in connection with any vehicle collisions or other structural degradation in connection with the use of such vehicle (on road or off road) will not be covered by the Aluminess warranty. Additionally, any product user's misuse, neglect, overloading, improper maintenance or improper installation or repair of any Aluminess products are not covered under the Aluminess warranty.
5. Use of the Products. Aluminess products are designed for off road vehicle use. Installing Aluminess products on a vehicle may exceed the factory designed capabilities of such vehicle and could potentially lead to vehicle damage. Aluminess will not be responsible for any damage caused to a purchaser or user's vehicle or any vehicle accessories caused by the use of any Aluminess products. It is to the sole responsibility of purchaser to inspect and ensure that the intended vehicle and Aluminess products are suitable and compatible for travel on road and off road. No seller nor any manufacturer of Aluminess products will be liable for any loss, damage or injury directly or indirectly arising from the use of any Aluminess products. Before using any Aluminess products, the purchaser or user will determine the suitability of the product(s) for their intended use(s) and the purchaser or user shall assume all responsibility and risk in connection therewith.
6. DISCLAIMER. THE ALUMINESS WARRANTY IS EXPRESSLY MADE IN LIEU OF ANY AND ALL OTHER WARRANTIES, AND EXCEPT FOR THE ALUMINESS WARRANTY SET FORTH HEREIN, ALUMINESS MAKES NO WARRANTY WHATSOEVER WITH RESPECT TO ANY ALUMINESS PRODUCT, INCLUDING ANY WARRANTY OF MERCHANTABILITY AND FITNESS FOR A PARTICULAR PURPOSE, WHETHER EXPRESS OR IMPLIED BY LAW, COURSE OF DEALING, COURSE OF PERFORMANCE, USAGE OF TRADE, OR OTHERWISE. EXCEPT FOR PURCHASER'S LIMITED REMEDIES SET FORTH HEREIN, IN NO EVENT WILL ALUMINESS BE LIABLE FOR ANY LOST PROFITS, LOST SALES, OR FOR ANY CONSEQUENTIAL, DIRECT, INDIRECT, INCIDENTAL, SPECIAL, EXEMPLARY OR PUNITIVE DAMAGES OR FOR ANY OTHER DAMAGES OF ANY KIND OR NATURE.
7. Compliance. Aluminess cannot guarantee that its products comply with all Federal, State, and/or local laws. Purchaser is advised to review local vehicle codes for compatibility prior to purchase to ensure that the installation and use of any Aluminess products does not violate any applicable laws.
8. Warranty Claim Submission. Purchaser will responsible for returning any defective product to Aluminess for warranty consideration and purchaser may be responsible for all costs associated with shipping the product to and from Aluminess. Prior to returning any product for warranty, purchaser must contact Aluminess Products Inc. for proper authorization.