

Front Receiver Installation Instructions

P/N 210513: 2019+ Mercedes Sprinter Front Receiver + Winch Mount

WARNING: Use extreme caution while winching - it can be very dangerous and every situation needs to be evaluated properly. The winchline can rub at extreme winching angles - use appropriate tools and techniques to avoid winchline damage.



Before you begin:

- *This product is compatible with the Sprinter 1500, 2500, and 3500. However, 3500s may require specialized tooling and/or additional hardware.*
- *Collision Prevention, DISTRONIC (adaptive cruise control), and/or front parking sensor systems may be impaired if accessories are installed into the front receiver. This includes roller fairleads, winchlines, recovery hooks, shackles, and/or license plates.*
- *This product is not currently compatible with the adaptive cruise control/collision prevention sensor. Additional sensor relocation kit is required – see PN 280101.*
- *A hawse fairlead is strongly recommended with use of hidden winch mount when installing with a winch.*
- *Stainless steel hardware may bind together when tightening — apply an anti-seize assembly lubricant to the threads of each bolt before assembly*

Required Tools:

- Standard and metric wrench set
- Standard and metric socket set
- Flat head screwdriver
- Hammer
- Putty knife
- Razor blade or box cutter
- Painter’s masking tape

Included Hardware:

P/N	Description	Quantity
70124	M8-1.25 x 40mm Bolt	10
70101	M8-1.25 Nut	8
70111	5/16" Split Locking Washer	10
70020	5/16" SS Washer	18
70036	½"-13 x 1-½" Hex Head Bolt, Grade 8	4
70103	½"-13 x 2 ½" Hex Head Screw, Grade 8	4
70035	½" Washer	16
70033	½"-13 Nylock Nut	8
70029	3/8"-16 x 1-1/4" Hex Head Bolt, SS	2
70028	3/8" ID SS Washer	4
70024	3/8"-16 Nylon-Locking Nut	2
70060	¼"-20 x 1" Button Head Bolt, SS	4
70014	¼"-20 x 1-1/4" Button Head Bolt, SS	4
70008	¼"-20 Nylock Nuts, SS	8
70009	¼" Flat Washers, SS	16
70246	Antiseize Bolt Lubricant Packet, 2g	1

Additional Parts:

Description

Quantity

Picture

Mounting Brackets

2 ea

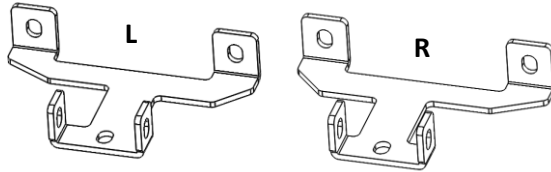

Tow Hooks, Steel

2 ea

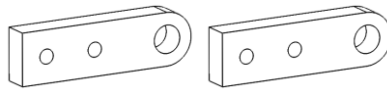

Light Bar Straps

2 ea
(L & R)

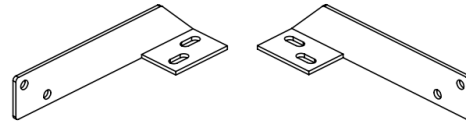

Winch Replacement Bracket

1 ea

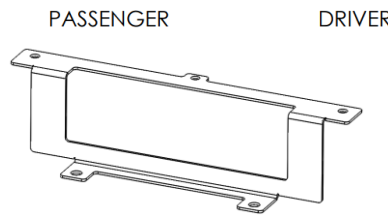

Bolt-On Fairlead Plate

1 ea

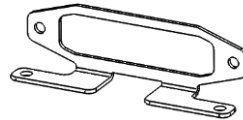

Euro Center Cut Template
(PN 301167)

1 ea



Euro Side Cut Templates
(PN 301166)

2 ea
(L & R)

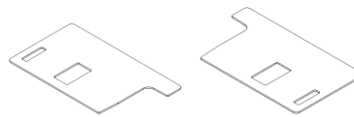

US Center Cut Template
(PN 301186)

1 ea



US Side Cut Templates
(PN 301185)

2 ea
(L & R)

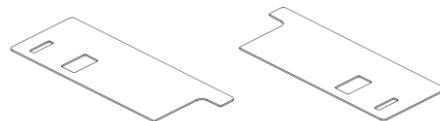

License Plate Holder

1 ea

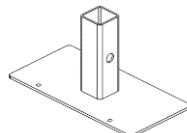

Stock Bumper Removal:

1. Open and secure the hood.
2. Remove the three (3) torx screws across the top of the grille; reference Figure 1.



Figure 1: Grille Screws

3. Pull the grille slightly away from the vehicle and unclip the grille in the six (6) indicated locations (see Figure 2 & Figure 3). Once all tabs have been released, the grille can be removed.



Figure 2: Grille Tab Locations



Figure 3: Grille Tab Close Up

4. Remove the two (2) torx bolts near the top of the stock bumper seen with the grille removed. Reference Figure 4.

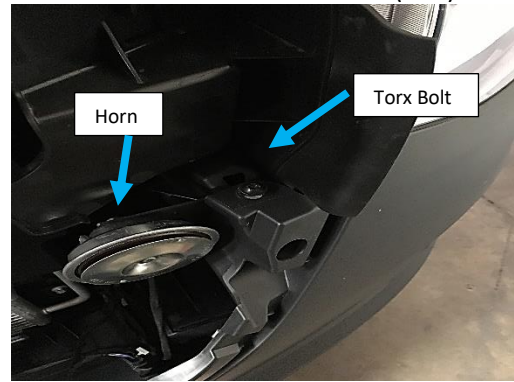

Figure 4: Torx Bolts Near Top of Stock Bumper

5. Remove the two (2) plastic caps on the front bumper step to reveal two (2) torx bolts. Do not yet remove torx bolts (reference Figure 5 & Figure 6).



Figure 5: Plastic Cap Location



Figure 6: Front Bumper Step with Plastic Cap Removed

6. Remove the six (6) plastic rivets on the inside of each fender well. Gently pull the center of the rivet out, then remove entire rivet. Reference Figure 7 - Figure 9.

PRO TIP: Access to the rivets is much easier by turning the vehicle's wheels.



Figure 7: Plastic Rivets on the Inside of the Wheel Well



Figure 8: Plastic Rivets on Underside of Bumper



Figure 9: Example of the Plastic Rivet

7. Pull gently on the corner of the plastic bumper directly away from the vehicle. Start in the corner nearest the wheel well working towards the center. Repeat for other side of vehicle. Reference Figure 10.



Figure 10: Removing Plastic Bumper

8. Remove the final two (2) torx bolt holding on the stock bumper on the bumper step as shown in Figure 6.
9. Remove stock front bumper by pulling directly away from vehicle being sure to disconnect any sensors that are attached.
10. Remove the horn (seen in Figure 4).
11. Remove the plastic shrouds on either side of the radiator by depressing the indicated tab and sliding each shroud up. Repeat for both driver and passenger sides. Reference Figure 11.

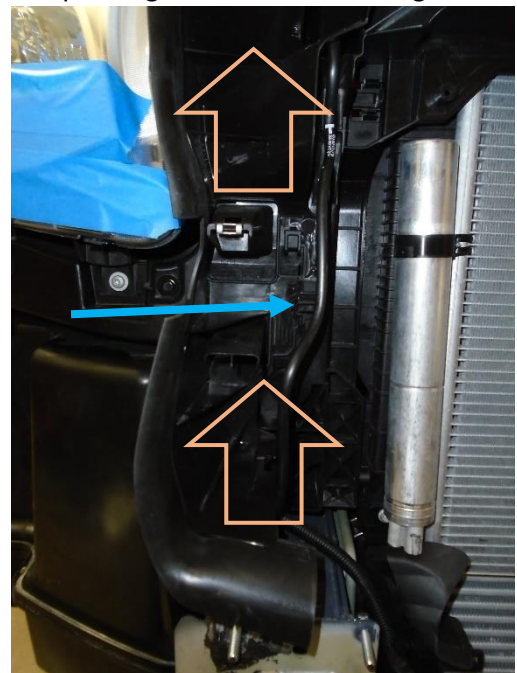

Figure 11: Plastic Shroud Removal

12. Remove the collision prevention sensor plastic bracket by unscrewing the two (2) torx bolts near the top of the radiator.

13. Remove the sensor from the plastic bracket.
14. Remove the eight (8) bolts holding the stock steel bumper in place using a 13mm wrench as shown in Figure 12.

CAUTION: Once all the bolts are removed, the bumper may fall if not properly supported.



Figure 12: Four (4) of the Frame Bolts Holding the Stock Steel Bumper to the Vehicle.

15. Remove the stock steel bumper using a putty knife and a hammer if the bumper does not come loose after removing the bolts in the previous step. The frame sealant may cause the steel bumper to stick to the frame. See Figure 13. **CAUTION:** once the seal is broken, the bumper may fall if not properly supported.

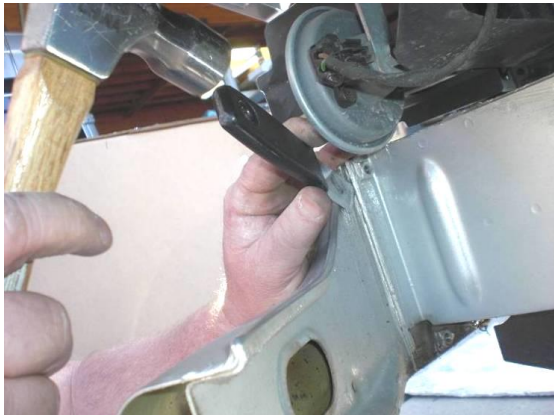

Figure 13: Releasing the Stock Steel Bumper from the Vehicle Using a Putty Knife and Hammer

16. Lower the air flow skirt by unclipping each side and pressing the skirt down as shown in Figure 14 - Figure 15. Some of the hoses may need to be adjusted.

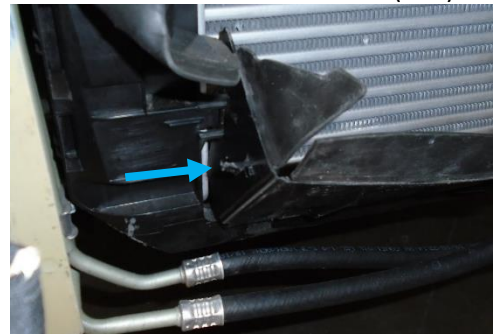

Figure 14: Air Flow Skirt Clip

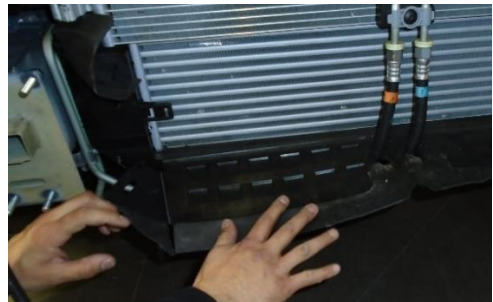

Figure 15: Air Flow Skirt Pressed Down

Front Receiver Installation:

17. Install the eight (8) provided M8 bolts with eight (8) split washers through the frame, from back to front, creating studs for the receiver to mount onto. Reference Figure 16.

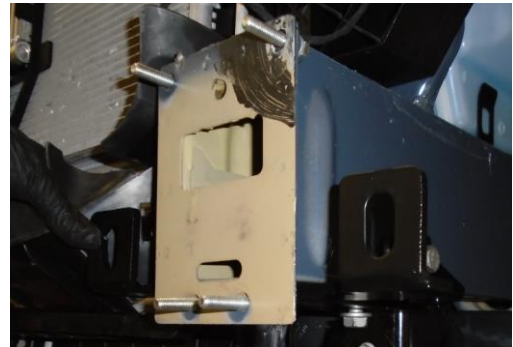

Figure 16: M8 Bolts Installed

18. Remove the bottom bolt and loosen the two (2) side bolts holding on each of the black steel crossmember underneath the radiator. (see Figure 17).

PRO TIP: Only uninstall one side at a time to make re-installation easier.

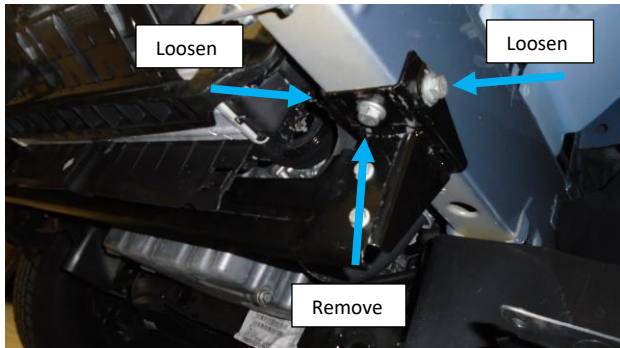

Figure 17: Engine Crossmember Bracket Factory Bolts (Driver Side Shown)

19. Install the steel mounting bracket (see “Additional Parts” section) on the correct side of the vehicle **over** each of the crossmember brackets.
20. Reinstall the factory hardware through the supplied mounting brackets and through the factory crossmember brackets. Do not tighten hardware yet; allow the mounting bracket some play until entire bumper is mounted. Reference Figure 18.

NOTE: Sprinter 3500 may or may not have these factory bolts and/or threaded inserts. Additional tapping and hardware may be required. At least **one** bolt is required on the bottom of the mounting bracket bolting into the *vehicles’ frame*.

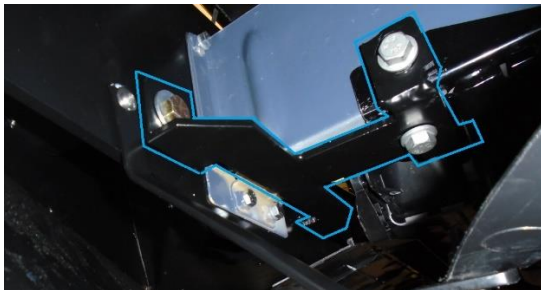

Figure 18: Installed Mounting Bracket

21. Press the air flow skirt down past the mounting brackets and adjust the hoses as needed.
22. Slide your Aluminess Front Receiver onto the (8) M8 bolts on the frame (Figure 19). Ensure the air flow skirt is resting below and behind the front receiver assembly.

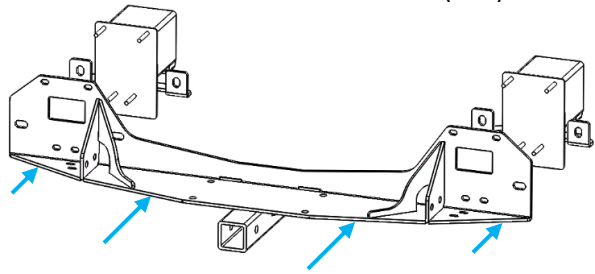

Figure 19: Slide receiver assembly onto frame mounts

23. Install washer, split washer, and M8 nuts onto the eight (8) pre-installed bolts.
24. Tighten two (2) of the M8 bolts, one (1) on each side, to hold the receiver in desired position.
25. Install ½”-13 bolts with washers through the mounting brackets and through the back of the receiver. Install a washer and nut onto each bolt.
26. Adjust receiver into final position.
27. Tighten all hardware:
 - a. ½”-13 bolts
 - b. M8 bolts
 - c. Factory bolts into frame at crossmember.

Winch Installation

(skip this step if you are not installing a winch on your van)

28. Install tow hooks into your front receiver using the ½”-13 hardware provided, along with accompanying nuts and washers (Figure 20).

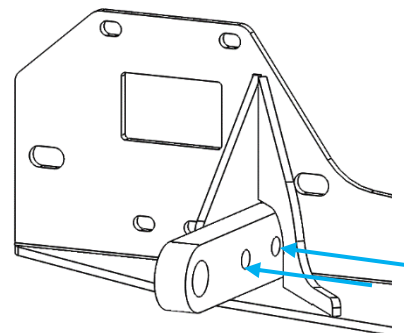

Figure 20: Tow Hook Installation

29. Install the bolt-on fairlead plate by sliding it over the front receiver and installing **underneath** the winch mounting surface (Figure 21).

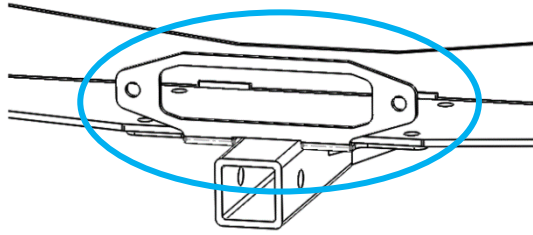

Figure 21: Bolt on Fairlead Plate

NOTE: A sensor relocation kit (PN 280101) is required if your vehicle has the front collision prevention sensor and /or adaptive cruise control.

30. Install your winch following the manufacturer's instructions.
31. With the winch already installed, install the fairlead provided with your winch.
 - a. Note: If you are running an Aluminess light bar, use a hawse fairlead instead of the provided winch fairlead (Figure 22).

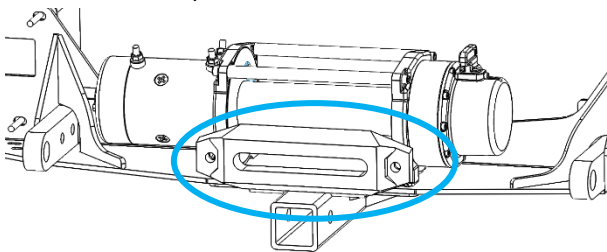

Figure 22: Bolt on Fairlead Plate

Hidden Winch Mount with Light Bar

(skip this step if your installing without a light bar)

32. Install Light Bar Straps onto the winch tray using the 1/4"-20 x 1" bolts with corresponding washer and nuts. Reference Figure 23.

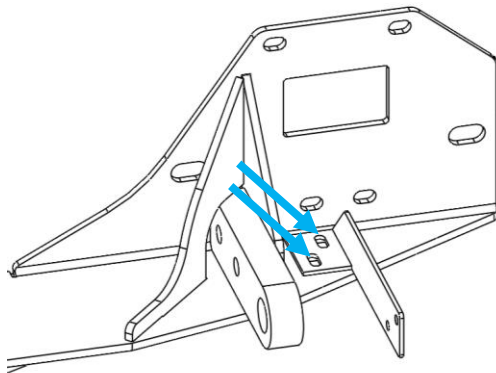

Figure 23: Light Bar Strap Installation Location

33. Follow the separately provided instructions for installation of the Aluminess Light Bar/Brush Guard (PN 280096), omitting the installation of the brackets onto the front step area of the factory bumper. Once the installation of the hidden winch mount and light are complete, drill a hole through the light bar supports using the light bars straps as a template. Reference Figure 24.

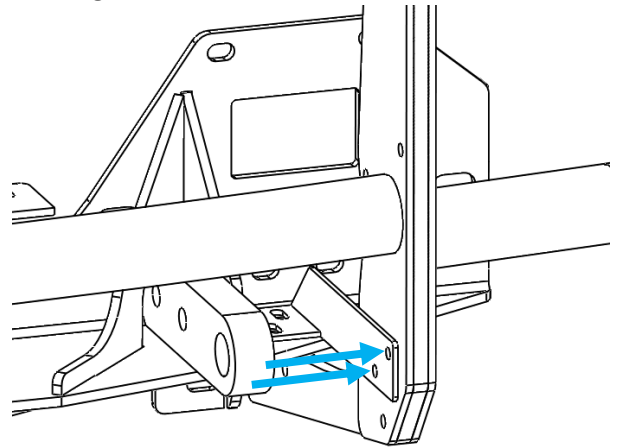

Figure 24: Drill Location on Light Bar Using Light Bar Straps

34. Install 1/4"-20 x 1-1/2" bolts with corresponding hardware through light bar straps and light bar supports (Figure 24).

Front Receiver Without Winch

(skip this if you are installing a winch)

35. With the Front Receiver bolted to the frame, install the provided Winch Replacement Bracket with 3/8"-16 bolts and accompanying nuts and washers (Figure 25).

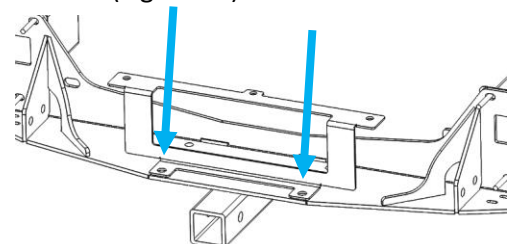

Figure 25: Winch Replacement Bracket

Factory Bumper Preparation and Reinstallation

36. Apply the cut templates to the front bumper as shown in Figure 26. Use the license plate mount to align stickers onto the bumper. Your vehicle will have either a long, narrow European license plate, or the short, wide US license plate mount. Use the corresponding cut templates.

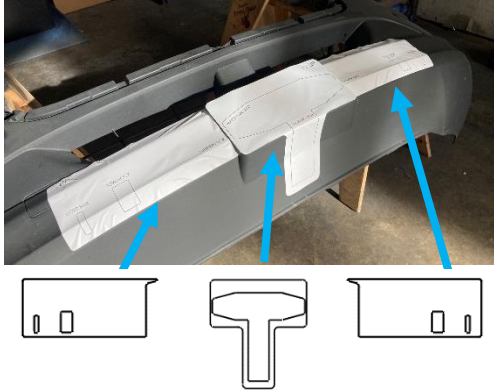
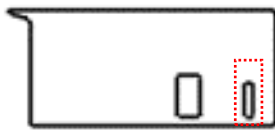

Figure 26: Cut Template Locations (US templates shown)

NOTE: Measure twice, cut once! Be sure to physically measure the distances of the protruding features on the hidden winch mount and compare them to the cut templates before cutting!

37. Using the cut templates, cut through the bumper along printed lines.
- NOTE: the outer most rectangles on the side templates are only used in conjunction with the **light bar**.



- NOTE: The inner rectangles on the side templates and octagonal shape on the middle template are only used in conjunction with the **winch/tow hooks**.

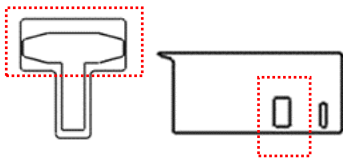

38. When installing a winch, additional material will need to be removed around the air intake hole

of the factory front bumper. Use Figure 27 & Figure 28 as a cutting/trimming guide.

- Remove the front step by pushing straight down.



Figure 27: Factory Front Step Removal

- Using the opening as guide, continue the cut through the back of the bumper. Trim all grill pieces out and trim center section out.

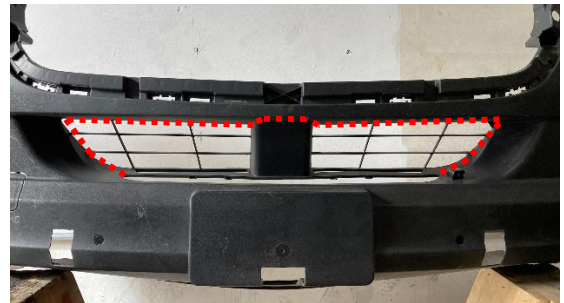

Figure 28: Factory Front Bumper Trimming Guide

NOTE: Additional trimming may be necessary to accommodate different models and manufacturers' winches. Use masking tape and a pen to mark areas needed for additional trimming and cut to fit.

- Reinstall the bumper onto the vehicle.
- Be sure to check hardware after the first 100 miles and periodically thereafter.
- Your new Aluminess Front Receiver + Winch Mount is now installed! Enjoy!



Aluminess Products, Inc. (Aluminess) Warranty

1. Lifetime Warranty. Aluminess provides a lifetime warranty of its products to the original retail purchaser provided such products are installed correctly according to the official Aluminess installation instructions. Any modification to the original product design, function or use of any Aluminess products will void the Aluminess warranty. Aluminess will have sole discretion to determine warranty eligibility for any and all Aluminess products sold to any purchaser.

2. Limited Remedies. Subject to any limitations and exclusions described herein, and subject to Aluminess' determination of warranty eligibility, Aluminess will remedy defects in product materials and/or workmanship of any product by repairing or replacing such defective product, which shall be within Aluminess' sole discretion, without charge for parts or labor. Aluminess may elect in its sole discretion not to replace a defective product and issue the purchaser a refund equal to the purchase price of any defective product or purchaser may elect to receive a credit (equal to such refund) toward the purchase of new Aluminess products. Repair or replacement of a defective product or providing a refund or credit to purchaser will be purchaser's exclusive remedy under this warranty. Damage to a purchaser's vehicle, cargo and/or any other person or property is expressly excluded from the Aluminess warranty.

3. Modification. Aluminess products are designed to be mounted to factory equipped vehicles. Aftermarket additions to such vehicle may or may not require modification of an Aluminess product. The Aluminess warranty does not extend to any Aluminess products that are modified to fit around other otherwise accommodate or be compatible with any aftermarket vehicle accessories or alterations. Aluminess does not guarantee fitment with any other aftermarket accessories or modified vehicle, and it is up to purchaser to determine fitment prior to purchasing any Aluminess product.

4. Damage. Damage to Aluminess products due to normal wear and tear, including, but not limited to, cosmetic issues and superficial scratches, or structural damage to an Aluminess product in connection with any vehicle collisions or other structural degradation in connection with the use of such vehicle (on road or off road) will not be covered by the Aluminess warranty. Additionally, any product user's misuse, neglect, overloading, improper maintenance or improper installation or repair of any Aluminess products are not covered under the Aluminess warranty.

5. Use of the Products. Aluminess products are designed for off road vehicle use. Installing Aluminess products on a vehicle may exceed the factory designed capabilities of such vehicle and could potentially lead to vehicle damage. Aluminess will not be responsible for any damage caused to a purchaser or user's vehicle or any vehicle accessories caused by the use of any Aluminess products. It is to the sole responsibility of purchaser to inspect and ensure that the intended vehicle and Aluminess products are suitable and compatible for travel on road and off road. No seller nor any manufacturer of Aluminess products will be liable for any loss, damage or injury directly or indirectly arising from the use of any Aluminess products. Before using any Aluminess products, the purchaser or user will determine the suitability of the product(s) for their intended use(s) and the purchaser or user shall assume all responsibility and risk in connection therewith.

6. DISCLAIMER. THE ALUMINESS WARRANTY IS EXPRESSLY MADE IN LIEU OF ANY AND ALL OTHER WARRANTIES, AND EXCEPT FOR THE ALUMINESS WARRANTY SET FORTH HEREIN, ALUMINESS MAKES NO WARRANTY WHATSOEVER WITH RESPECT TO ANY ALUMINESS PRODUCT, INCLUDING ANY WARRANTY OF MERCHANTABILITY AND FITNESS FOR A PARTICULAR PURPOSE, WHETHER EXPRESS OR IMPLIED BY LAW, COURSE OF DEALING, COURSE OF PERFORMANCE, USAGE OF TRADE, OR OTHERWISE.

EXCEPT FOR PURCHASER'S LIMITED REMEDIES SET FORTH HEREIN, IN NO EVENT WILL ALUMINESS BE LIABLE FOR ANY LOST PROFITS, LOST SALES, OR FOR ANY CONSEQUENTIAL, DIRECT, INDIRECT, INCIDENTAL, SPECIAL, EXEMPLARY OR PUNITIVE DAMAGES OR FOR ANY OTHER DAMAGES OF ANY KIND OR NATURE.

7. Compliance. Aluminess cannot guarantee that its products comply with all Federal, State, and/or local laws. Purchaser is advised to review local vehicle codes for compatibility prior to purchase to ensure that the installation and use of any Aluminess products does not violate any applicable laws.

8. Warranty Claim Submission. Purchaser will responsible for returning any defective product to Aluminess for warranty consideration and purchaser may be responsible for all costs associated with shipping the product to and from Aluminess. Prior to returning any product for warranty, purchaser must contact Aluminess Products Inc. for proper authorization.