

NERF BAR INSTALLATION INSTRUCTIONS **2003-2020 GMC/CHEVY VAN**

Please read before beginning

- *Stainless steel hardware may bind together when tightening—It is recommended that you apply an anti-seize assembly lubricant to the threads of each bolt before assembly*
- *This installation requires two people*



Required tools

- Standard wrench set
- Drill, with 1/4" drill bit

Included hardware

Quantity

- | | |
|---|----|
| • 70008 - 1/4-20 Stainless steel nuts with nylon locking insert | 12 |
| • 70009 - 1/4 x 5/8 Washer | 26 |
| • 70088 – 1/4-20 X 5 1/2" Hex Bolt | 4 |
| • 70089 – 1/4-20 x 4" Hex Bolt | 2 |
| • 70119 - 1/4-20 x 2" Button head socket cap screw | 6 |
| • 70024 – 3/8-16 Nylock Nut, SS | 22 |
| • 70028 – 3/8" Flat Washer, SS | 44 |
| • 70029 – 3/8-16 x 1 1/4" Hex Head Bolt, SS | 22 |
| • Antiseize Packet, 2g | 1 |

Included Parts/Subassemblies

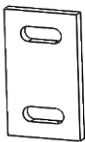

X3
 Aluminum Backing
 Plates

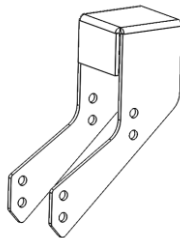

X3
 Ford/Chevy Nerf Bar
 Bracket

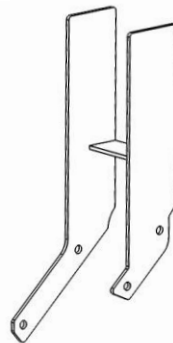

X1
 Chevy Rear Bracket
 Assy Driver

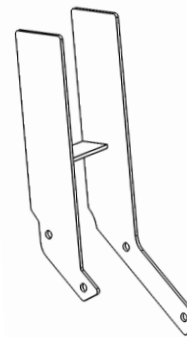

X1
 Chevy Rear Bracket
 Assy Passenger



X1
 Chevy Mid Blade

Installation Instructions

1. Assemble the nerf bar brackets into the correct orientations shown in Figure 1. The passenger side and driver side nerf bars will assemble differently, be sure to note the differences outlined in Figure 1.
 - Some nerf bar brackets will have two sets of holes; you will need to utilize the correct set of holes for each bracket to ensure the correct bracket height when mounting.
 - Use the 3/8-16 x 1 1/4" bolts, along with accompanying nuts and washers, to fasten the brackets to the nerf bar assembly.

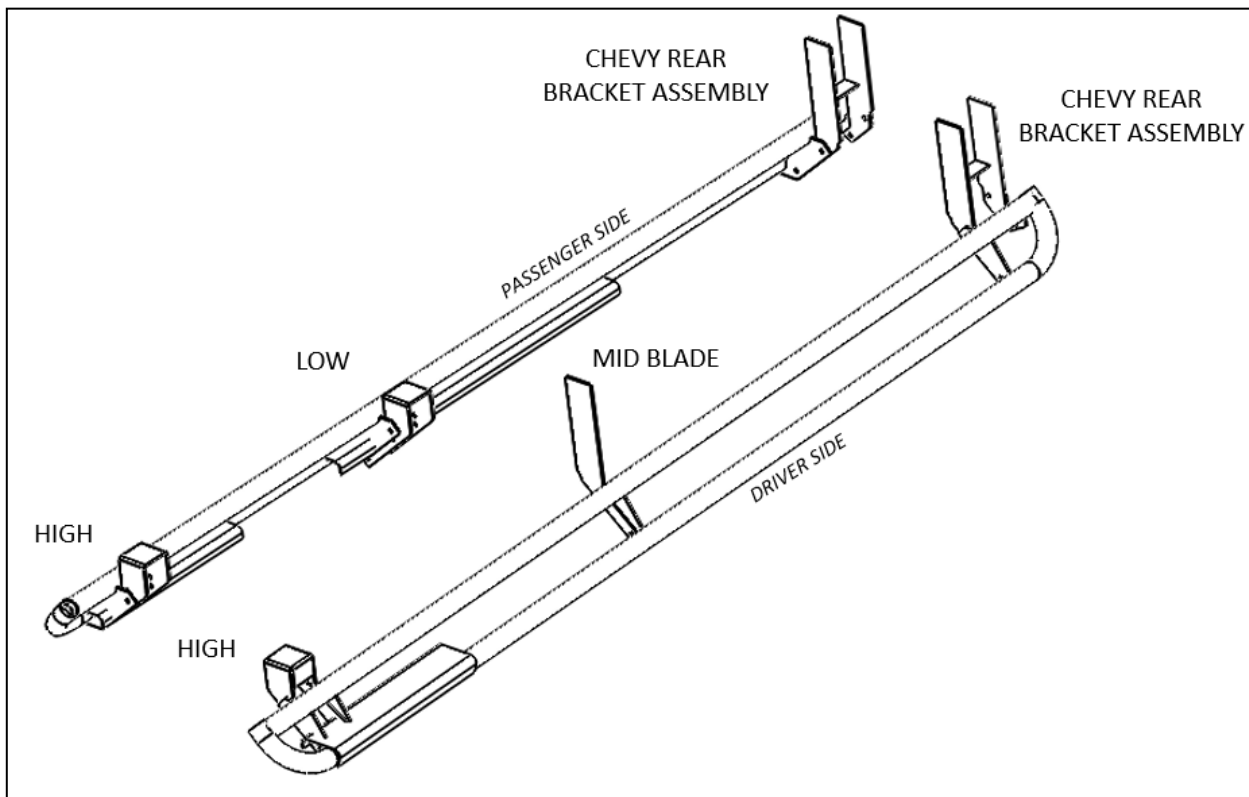
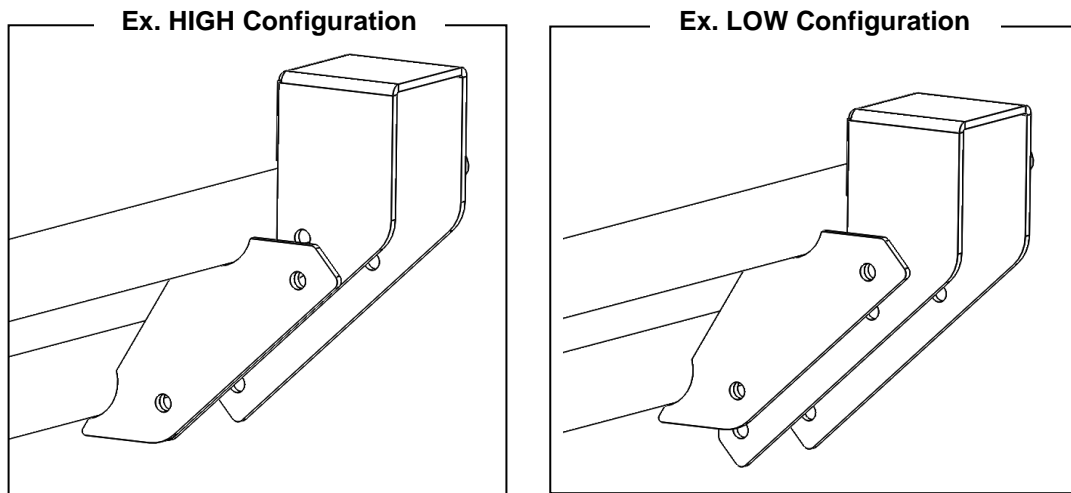

Figure 1. Correct orientation of mounting brackets for Chevy 155 Nerf Bars.

2. Once your nerf bars are fully assembled, begin installation on the driver's side.
3. Remove the plastic step on the driver side found just inside the driver's door (take note of any wiring because you will be drilling in this area).
4. Hold the nerf bar up oriented correctly.
 - The front mounting bracket should be held up against the step (see figure 3) and the rear mounting bracket should be on either side of the stock van channel (see figure 4).

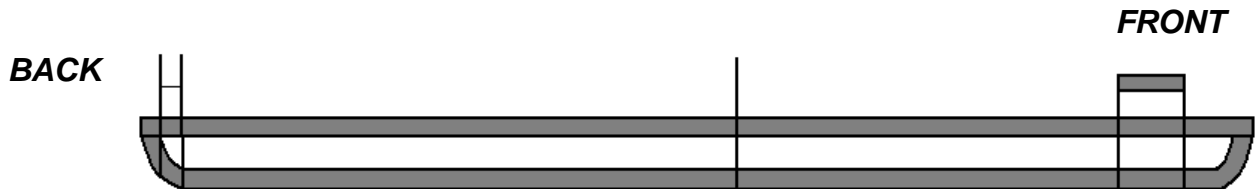

Figure 2

5. Front Mounting Bracket:
 - With the front mounting bracket held up against the step.
 - Drill through the bracket and the step with a 1/4" drill bit (be careful of any wiring that may be on the top of the step).
 - After drilling the first hole insert a 1/4-20 x 2" Button Socket Cap through the Slotted Aluminum plate hole (See figure 2.a), with a flat washer on both sides, and a 1/4-20 Nylock Nut.



Figure 2.a

- The head of the bolt should be on the top of the step (i.e. the bolt is going down and the nut is on the bottom of the vehicle).
- Repeat steps "ii" and "iii" until there are two bolts attaching the front mounting bracket to the bottom of the step.



Figure 3

6. Rear Mounting Bracket:

- With the rear mounting brackets on either side of the cross-beam drill through both sides of the mounting bracket and the crossbeam with a $\frac{1}{4}$ " bit.



Figure 4

- After drilling the first hole insert a $\frac{1}{4}$ -20 x 5 $\frac{1}{2}$ " Hex Bolt through the hole, with a washer on either side, and $\frac{1}{4}$ "-20 Nylock Nut on the end.
 - There are two extra washers for each 5" bolt for spacer if needed.
- Repeat steps "i" and "ii" so that there are two bolt holding the rear mounting bracket to the crossbeam (Try to offset these two bolts, top right and bottom left to help reduce "play" in the nerf bars).

7. Middle Mounting Bracket:



- Follow the same procedure outlined in step “d” to attach the middle bracket to the vehicle, using the ¼-20 x 4” Hex Bolt.
 - There are two extra washers for each 4” bolt for spacer if needed
- The Middle Mounting Bracket on the driver side, has a single Blade to attach to the body of the vehicle.

- Passenger Side

1. The steps are the same for the passenger side except:



- The Middle Bracket on the passenger side is mounted the same way as the front brackets on both driver and passenger side.
- Drill through the bracket and the step with a ¼” drill bit (be careful of any wiring that may be on the top of the step).
- After drilling the first hole insert a ¼-20 x 2” Button Socket Cap through the Slotted Aluminum plate hole (See figure 2.a), with a flat washer on both sides, and a ¼-20 Nylock Nut.
 - The head of the bolt should be on the top of the step (i.e. the bolt is going down and the nut is on the bottom of the vehicle).
- Repeat steps “ii” and “iii” until there are two bolts attaching the front mounting bracket to the bottom of the step



Figure 1.a

- For the rear mounting Procedures, follow steps 1-d as seen above for the driver side section.



Aluminess Products, Inc. (Aluminess) Warranty

1. Lifetime Warranty. Aluminess provides a lifetime warranty of its products to the original retail purchaser provided such products are installed correctly according to the official Aluminess installation instructions. Any modification to the original product design, function or use of any Aluminess products will void the Aluminess warranty. Aluminess will have sole discretion to determine warranty eligibility for any and all Aluminess products sold to any purchaser.
2. Limited Remedies. Subject to any limitations and exclusions described herein, and subject to Aluminess' determination of warranty eligibility, Aluminess will remedy defects in product materials and/or workmanship of any product by repairing or replacing such defective product, which shall be within Aluminess' sole discretion, without charge for parts or labor. Aluminess may elect in its sole discretion not to replace a defective product and issue the purchaser a refund equal to the purchase price of any defective product or purchaser may elect to receive a credit (equal to such refund) toward the purchase of new Aluminess products. Repair or replacement of a defective product or providing a refund or credit to purchaser will be purchaser's exclusive remedy under this warranty. Damage to a purchaser's vehicle, cargo and/or any other person or property is expressly excluded from the Aluminess warranty.
3. Modification. Aluminess products are designed to be mounted to factory equipped vehicles. Aftermarket additions to such vehicle may or may not require modification of an Aluminess product. The Aluminess warranty does not extend to any Aluminess products that are modified to fit around other otherwise accommodate or be compatible with any aftermarket vehicle accessories or alterations. Aluminess does not guarantee fitment with any other aftermarket accessories or modified vehicle, and it is up to purchaser to determine fitment prior to purchasing any Aluminess product.
4. Damage. Damage to Aluminess products due to normal wear and tear, including, but not limited to, cosmetic issues and superficial scratches, or structural damage to an Aluminess product in connection with any vehicle collisions or other structural degradation in connection with the use of such vehicle (on road or off road) will not be covered by the Aluminess warranty. Additionally, any product user's misuse, neglect, overloading, improper maintenance or improper installation or repair of any Aluminess products are not covered under the Aluminess warranty.
5. Use of the Products. Aluminess products are designed for off road vehicle use. Installing Aluminess products on a vehicle may exceed the factory designed capabilities of such vehicle and could potentially lead to vehicle damage. Aluminess will not be responsible for any damage caused to a purchaser or user's vehicle or any vehicle accessories caused by the use of any Aluminess products. It is to the sole responsibility of purchaser to inspect and ensure that the intended vehicle and Aluminess products are suitable and compatible for travel on road and off road. No seller nor any manufacturer of Aluminess products will be liable for any loss, damage or injury directly or indirectly arising from the use of any Aluminess products. Before using any Aluminess products, the purchaser or user will determine the suitability of the product(s) for their intended use(s) and the purchaser or user shall assume all responsibility and risk in connection therewith.
6. DISCLAIMER. THE ALUMINESS WARRANTY IS EXPRESSLY MADE IN LIEU OF ANY AND ALL OTHER WARRANTIES, AND EXCEPT FOR THE ALUMINESS WARRANTY SET FORTH HEREIN, ALUMINESS MAKES NO WARRANTY WHATSOEVER WITH RESPECT TO ANY ALUMINESS PRODUCT, INCLUDING ANY WARRANTY OF MERCHANTABILITY AND FITNESS FOR A PARTICULAR PURPOSE, WHETHER EXPRESS OR IMPLIED BY LAW, COURSE OF DEALING, COURSE OF PERFORMANCE, USAGE OF TRADE, OR OTHERWISE.
EXCEPT FOR PURCHASER'S LIMITED REMEDIES SET FORTH HEREIN, IN NO EVENT WILL ALUMINESS BE LIABLE FOR ANY LOST PROFITS, LOST SALES, OR FOR ANY CONSEQUENTIAL, DIRECT, INDIRECT, INCIDENTAL, SPECIAL, EXEMPLARY OR PUNITIVE DAMAGES OR FOR ANY OTHER DAMAGES OF ANY KIND OR NATURE.
7. Compliance. Aluminess cannot guarantee that its products comply with all Federal, State, and/or local laws. Purchaser is advised to review local vehicle codes for compatibility prior to purchase to ensure that the installation and use of any Aluminess products does not violate any applicable laws.
8. Warranty Claim Submission. Purchaser will responsible for returning any defective product to Aluminess for warranty consideration and purchaser may be responsible for all costs associated with shipping the product to and from Aluminess. Prior to returning any product for warranty, purchaser must contact Aluminess Products Inc. for proper authorization.